

**Photoelectric Sensor**  
**BOS 15K-R-C10-P-S 75**  
**Sn=100mm**  
**Diffuse**

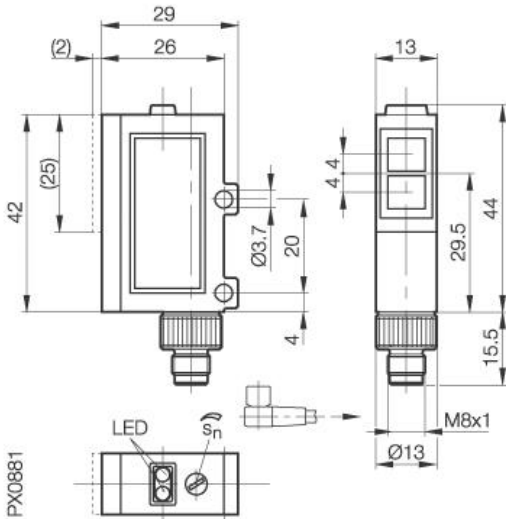

**Common Data**

Series	15K
Sensortype	Diffuse
Switching frequency	500 Hz
Rated operating distance Sn in mm	100
asured operating distance Sa	80% from Sn
Repeat accuracy	< 5% from Sn
Hysteresis	< 20%
Indication Supply Voltage	no
Indication Switching element on	yes, red LED
Indication Special funktion	LED green Stability indicator
Ambient temperature	-15...+55°C
On-delay	< 1 ms
Off-delay	< 1 ms
Light	Infrared
Sensitivity Adjustment	Poti
Blind zone / min Reflector distance	1mm
Special funktion	Stabilization indicator
Permissible ambient light	3000 Lux
Output function	light-on or dark-on

**Mechanical Data**

Measurements	29x52x13
Shock	Halfsinus, 30gn, 11ms
Vibration	10...55Hz, 1,5mm Amplitude 3x2h
Housing material	ABS UL 94 V-O
Material of sensing face	PMMA
Degree of protection	IP66
Connection	Connector S75 (M8,4-pin)
Weigth	30g

**Electrical Data**

Current	DC
Switching function	NO/NC
Output	PNP
Rated operational voltage Ue	24V DC
Rated operational current Ie	100mA
Supply Voltage	10...30V DC
Ripple	max. 6% from UB
Frequency of Supply Voltage	DC
Voltage drop	<1,5V
Short protection	yes
Protected against polarity reversal	no
Rated insulation voltage	75VDC
max. Load capacity	0,5 µF

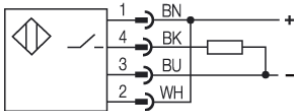

Utilization categories  
 Insulation class

Datasheet number:

Definitions see general catalog.  
 If not otherwise noted, ratings according to  
 IEC 60947-5-2 (DIN EN60947-5-2)

Balluff GmbH  
 Schurwaldstrasse 9  
 73765 Neuhausen a.d.F.  
 Phone (07158) 173-0 Fax (07158) 5010

Datenblatt by CD-ROM - 04/2007

**BALLUFF**  
 sensors worldwide